



**Machine Power Requirements**

190-250 VAC, 1PH, 50/60Hz, 15A

**Operator PC Power Requirements**

100-240VAC, 1PH, 50/60Hz, 3A  
 Supplied with 115VAC U.S. plugs

NAME	DATE	Mad Series Plasma Table	
DKH	10/2016		
		Sheet Name: Cover Sheet	Rev: 1
		Date: 10/10/2016	Sheet 1 of 6 Size: Letter



100  
110  
120  
130  
140  
150  
160  
170  
180  
190  
200  
210  
220  
230  
240  
250  
260  
270  
280  
290  
300  
310  
320  
330  
340  
350  
360  
370  
380  
390  
400  
410  
420  
430  
440

**POWER ENTRY**  
Wires supplied by end user

Connect to M5 ground bolt in backplane by cable entrance.

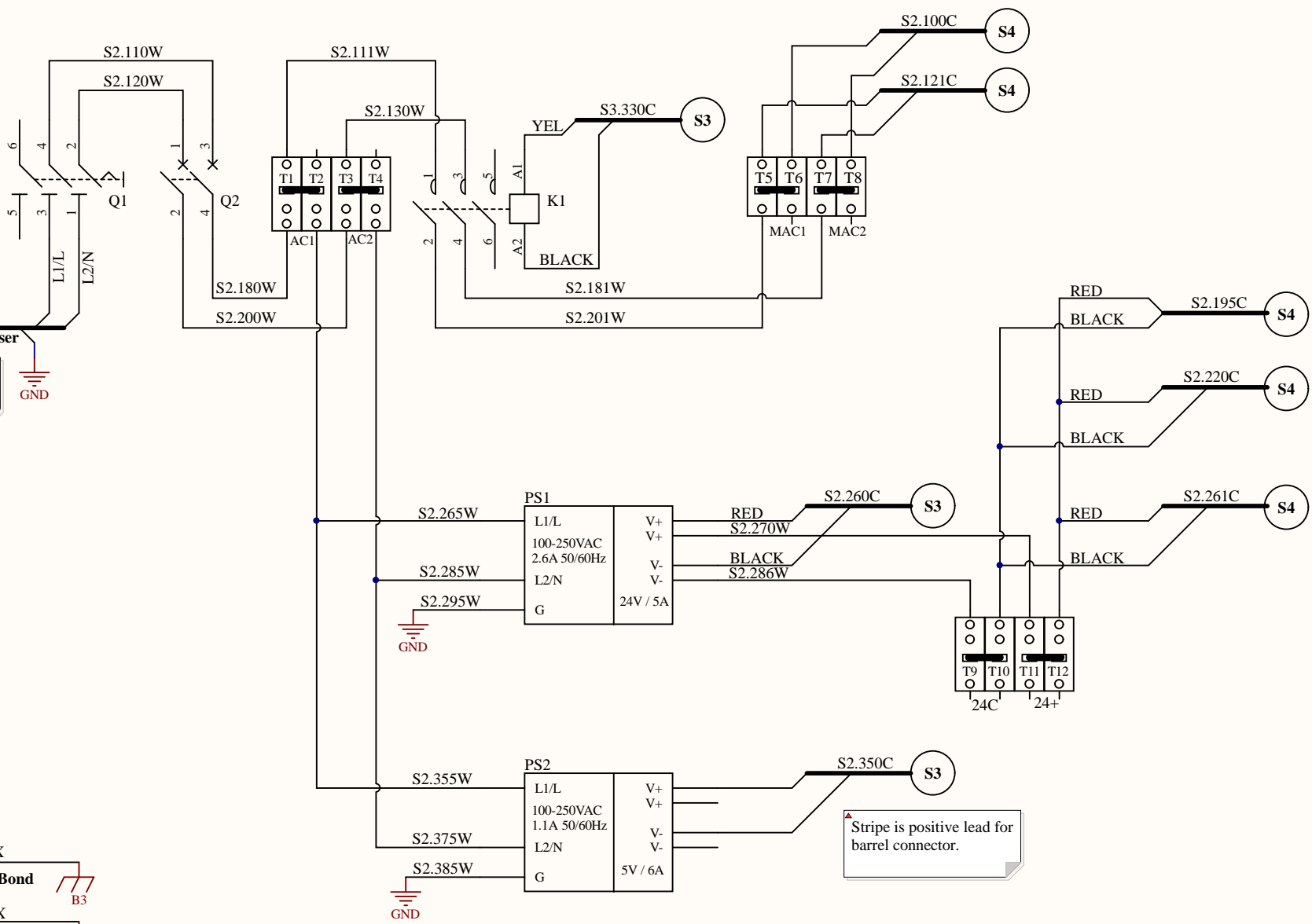

Stripe is positive lead for barrel connector.

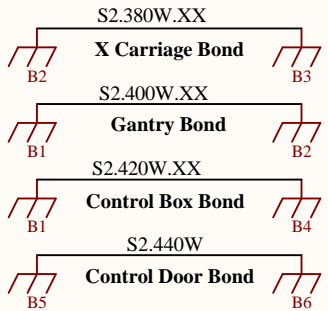

Table Size	XX
4' x 4'	44
4' x 8'	48
5' x 10'	51

NAME	DATE
DKH	10/2016

**Mad Series Plasma Table**

Sheet Name: Power Distribution      Rev: 1

Date: 10/10/2016      Sheet 2 of 6      Size: Letter



100  
110  
120  
130  
140  
150  
160  
170  
180  
190  
200  
210  
220  
230  
240  
250  
260  
270  
280  
290  
300  
310  
320  
330  
340  
350  
360  
370  
380  
390  
400  
410  
420  
430  
440

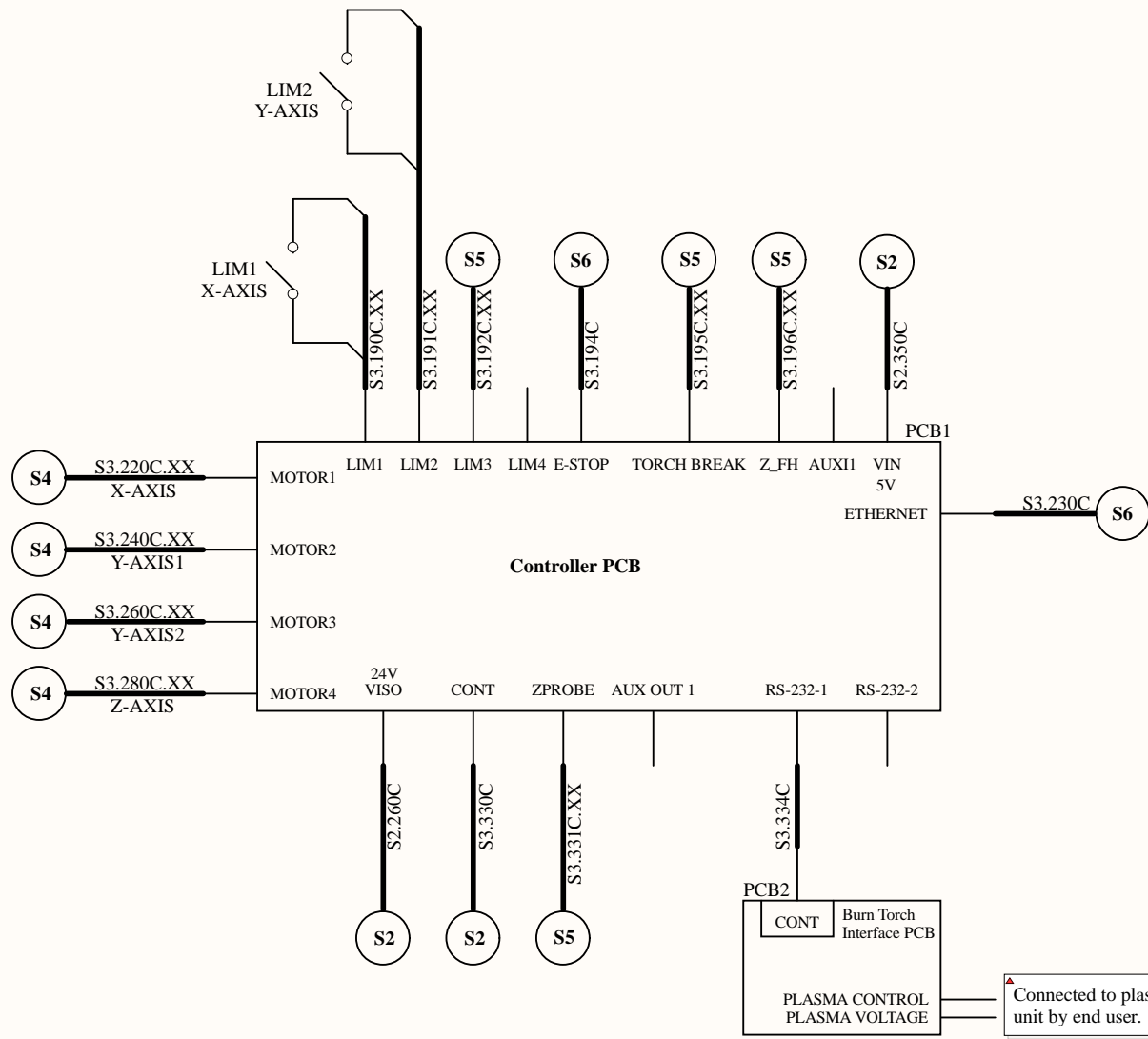

Table Size	XX
4' x 4'	44
4' x 8'	48
5' x 10'	51

NAME	DATE
DKH	10/2016

### Mad Series Plasma Table

Sheet Name: Controller

Rev: 1

Date: 10/10/2016

Sheet 3 of 6

Size: Letter



A

A

B

B

C

C

D

D

100  
110  
120  
130  
140  
150  
160  
170  
180  
190  
200  
210  
220  
230  
240  
250  
260  
270  
280  
290  
300  
310  
320  
330  
340  
350  
360  
370  
380  
390  
400  
410  
420  
430  
440

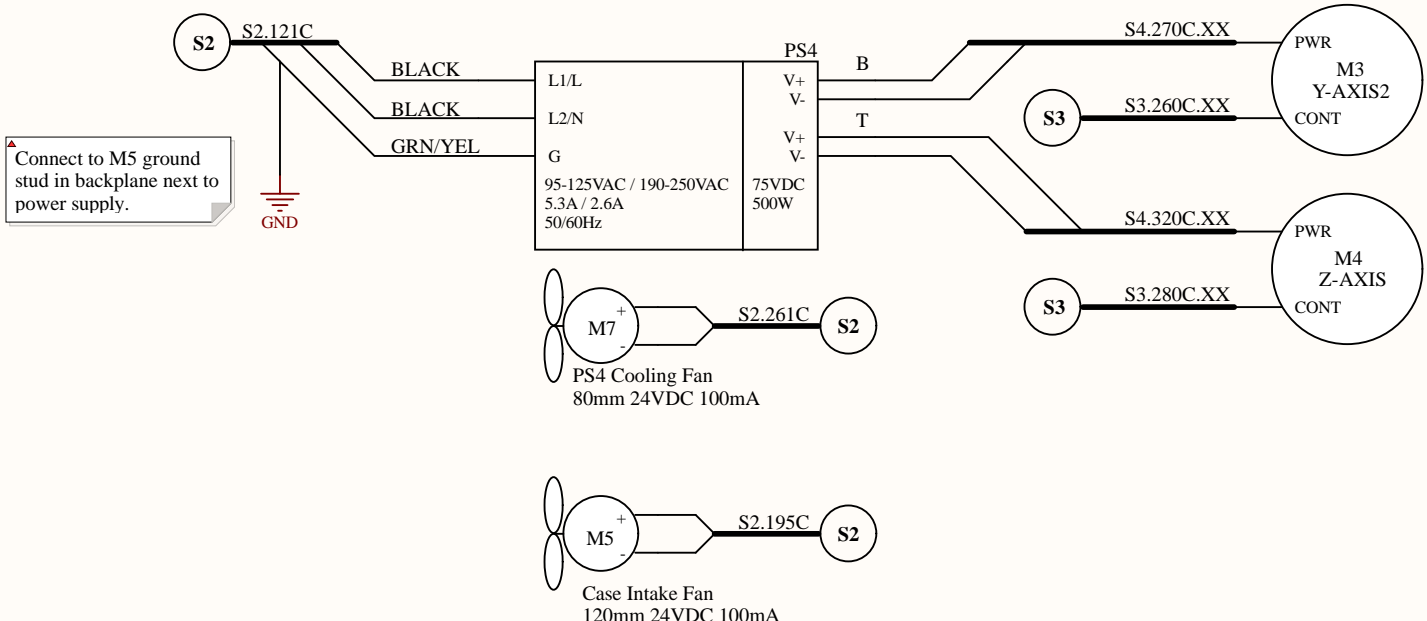
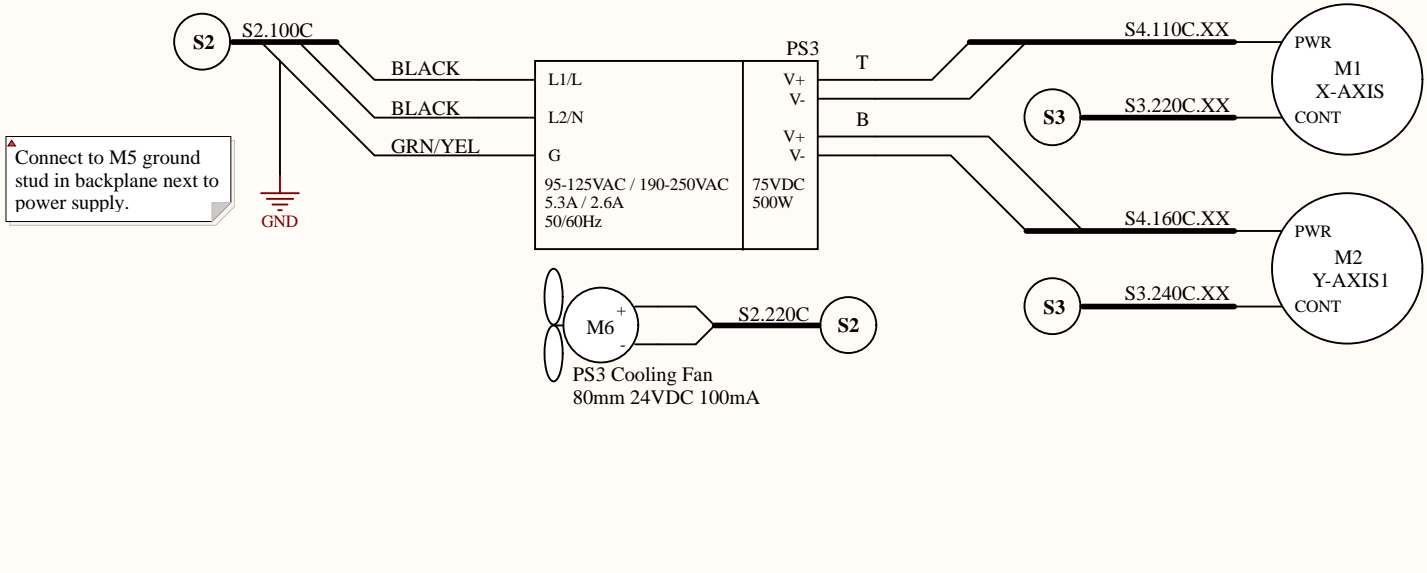

Table Size	XX
4' x 4'	44
4' x 8'	48
5' x 10'	51

NAME	DATE
DKH	10/2016

Mad Series Plasma Table		
Sheet Name: Servo Motors		Rev: 1
Date: 10/10/2016	Sheet 4 of 6	Size: Letter



100  
110  
120  
130  
140  
150  
160  
170  
180  
190  
200  
210  
220  
230  
240  
250  
260  
270  
280  
290  
300  
310  
320  
330  
340  
350  
360  
370  
380  
390  
400  
410  
420  
430  
440

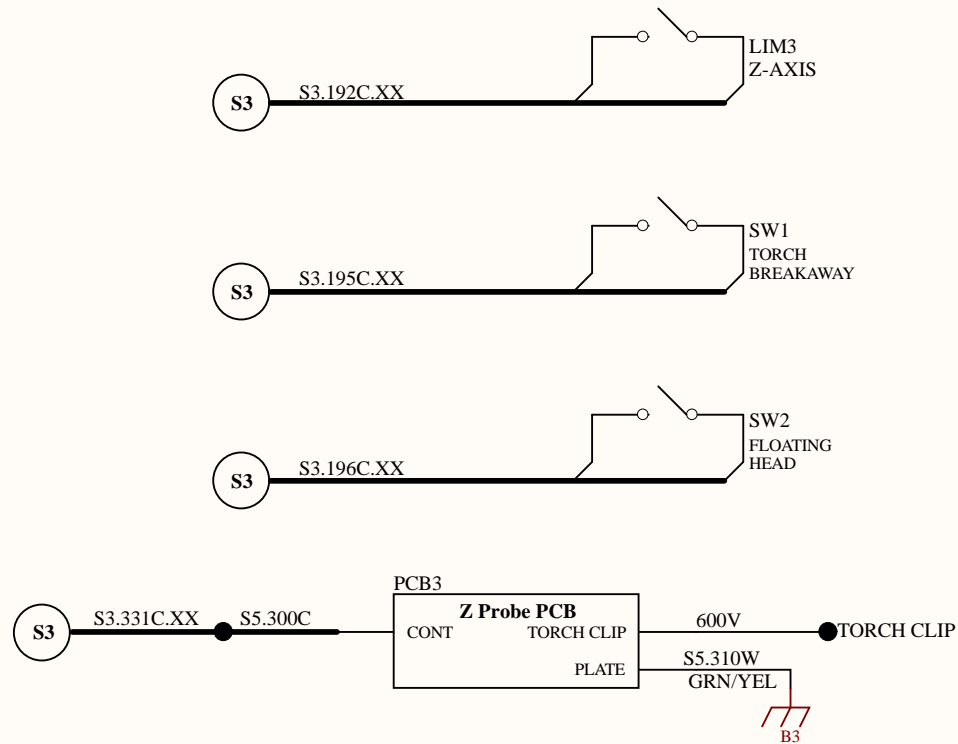

Table Size	XX
4' x 4'	44
4' x 8'	48
5' x 10'	51

NAME	DATE
DKH	10/2016

Mad Series Plasma Table		
Sheet Name: Controller		Rev: 1
Date: 10/10/2016	Sheet 5 of 6	Size: Letter



100  
110  
120  
130  
140  
150  
160  
170  
180  
190  
200  
210  
220  
230  
240  
250  
260  
270  
280  
290  
300  
310  
320  
330  
340  
350  
360  
370  
380  
390  
400  
410  
420  
430  
440

### USER CONTROL PC

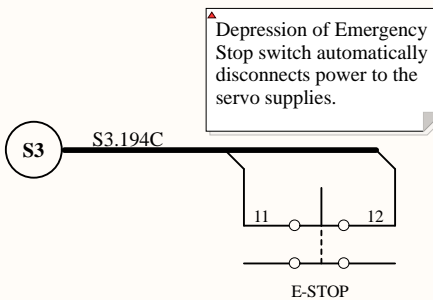
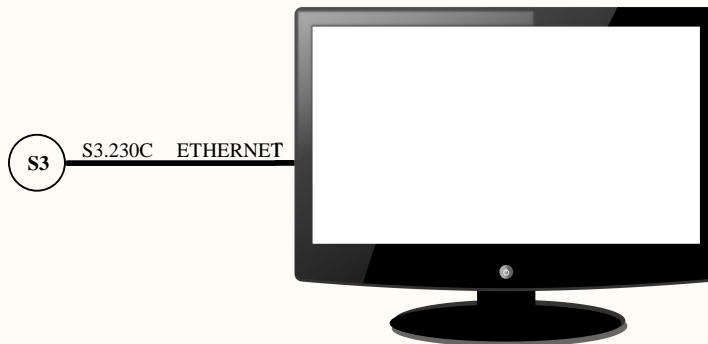

Table Size	XX
4' x 4'	44
4' x 8'	48
5' x 10'	51

NAME	DATE
DKH	10/2016

Mad Series Plasma Table		
Sheet Name: Operator Station		Rev: 1
Date: 10/10/2016	Sheet 6 of 6	Size: Letter

